

CLASSIC IFP V210/V230 PUMPS



★ Q.C. Assured

INTERNATIONAL FPA is proud of its hard-earned reputation for producing top quality products to the Fluid Power Industry at substantial savings over its closest competitors.

Features

- Improved pressure & speed (2500 PSI / 3400 RPM)
- Wide variety of displacements (5 to 13 GPM)
- Flow control / Priority covers available
- Suitable for Mobile & Industrial applications
- Interchangeable Replacement Parts

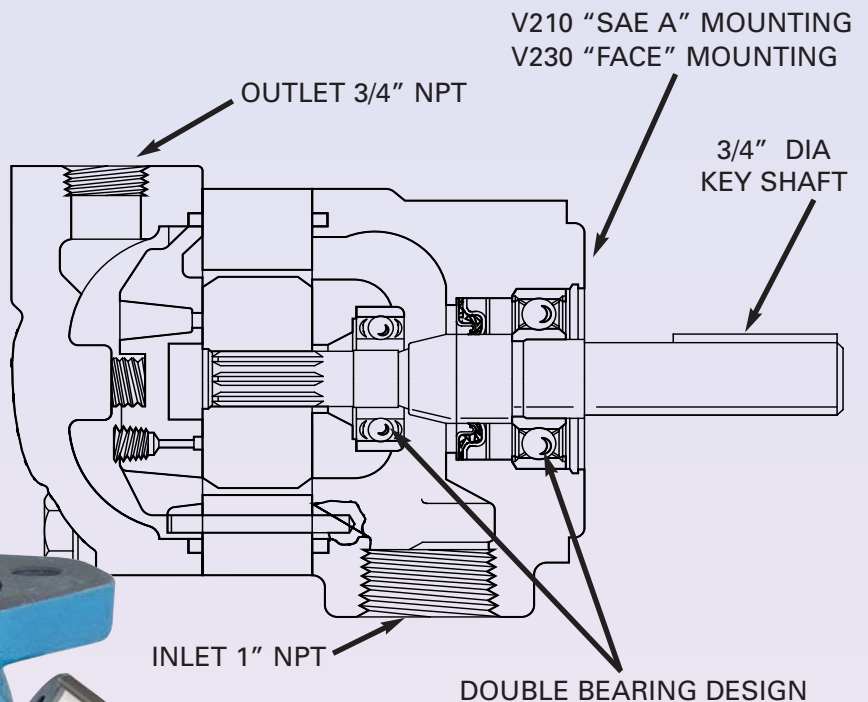

**CONTACT IFP
FOR ALL
YOUR SHAFT
REQUIREMENTS**

43105 Business Park Drive
Temecula, CA 92590 USA

West Coast Toll Free: (800) 432-6405

Visit our updated Website: www.intlfp.com

COAST TO COAST LOCATION

TO BETTER SERVICE YOUR REQUIREMENTS

Toll Free Ph: (888) 220-1414

Toll Free Fax: (888) 220-1415

4600 Garand, Montreal
Qc, Canada H4R 2A2

East Coast Toll Free: (800) 363-8446

E-Mail: info@intlfp.com