

IFP VANE MOTOR M2-210

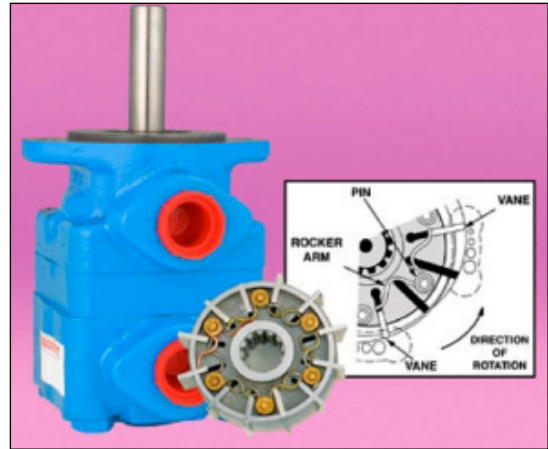

- * Spring loaded vanes for improved/smooth operation
- * Higher pressure & speed (2500 PSI/2800 RPM)
- * Wide operating speed range (100-2800 RPM)
- * Pressure balanced for long service life
- * Bi rotational
- * Low noise

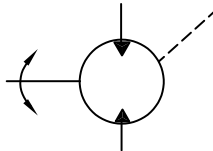

◆ Motor Ordering Specifications

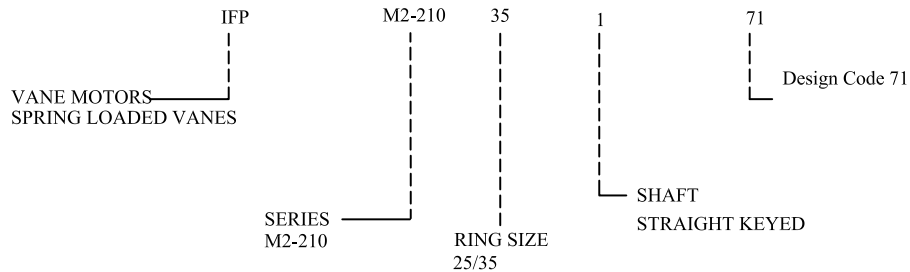

OPERATING SPECIFICATIONS

Model Series	Ring Size in/lb Torque per 100 PSI	Displacement cu. in/rev	US GPM req'd @ 1200 rpm	Maximum Torque lb. in @ max pressure	Maximum Speed & Pressure	Weight lbs
M2-210	25	1.51	8	500	2200 rpm/psi	21
	35	2.16	12	612.5	1800/1750 psi	21

IFP offers M2-210 spring loaded vane motors for industrial and mobile applications. The wide range of speeds and pressure make them ideal for most motor applications. Motors are constructed with spring loaded vanes offering smooth operation over a wide speed rang. Motors can be reversed or stalled under load without damage to the unit when proper relief protection is applied. A full size unrestricted drain line must be connected directly from case drain to reservoir return located below the lowest fluid level in the system. Factory tested cartridge kits are available, providing efficient field serviceability, avoiding costly down time and increased productivity.

IFP M2-210 VANE MOTOR DIMENSIONS DRAWING

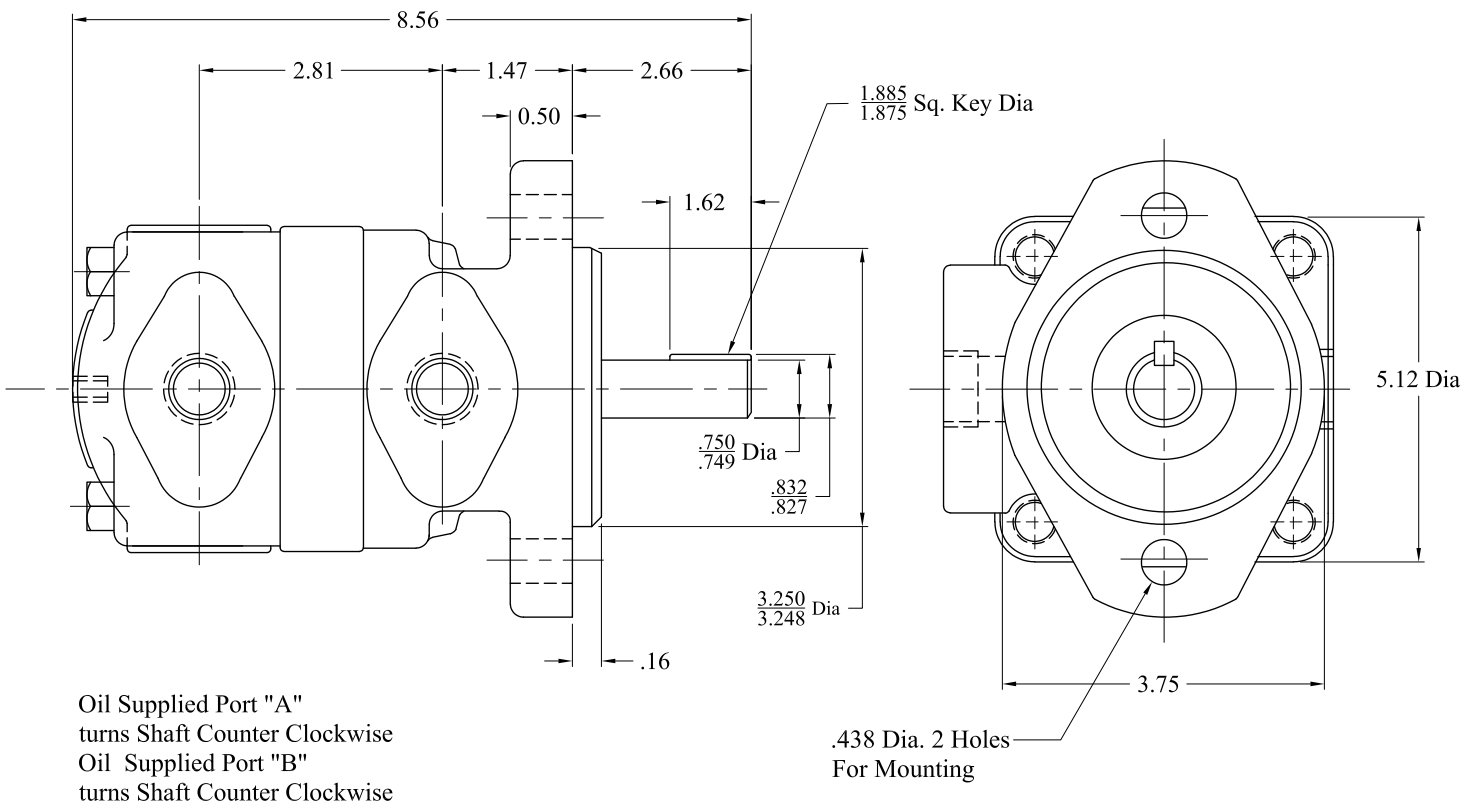
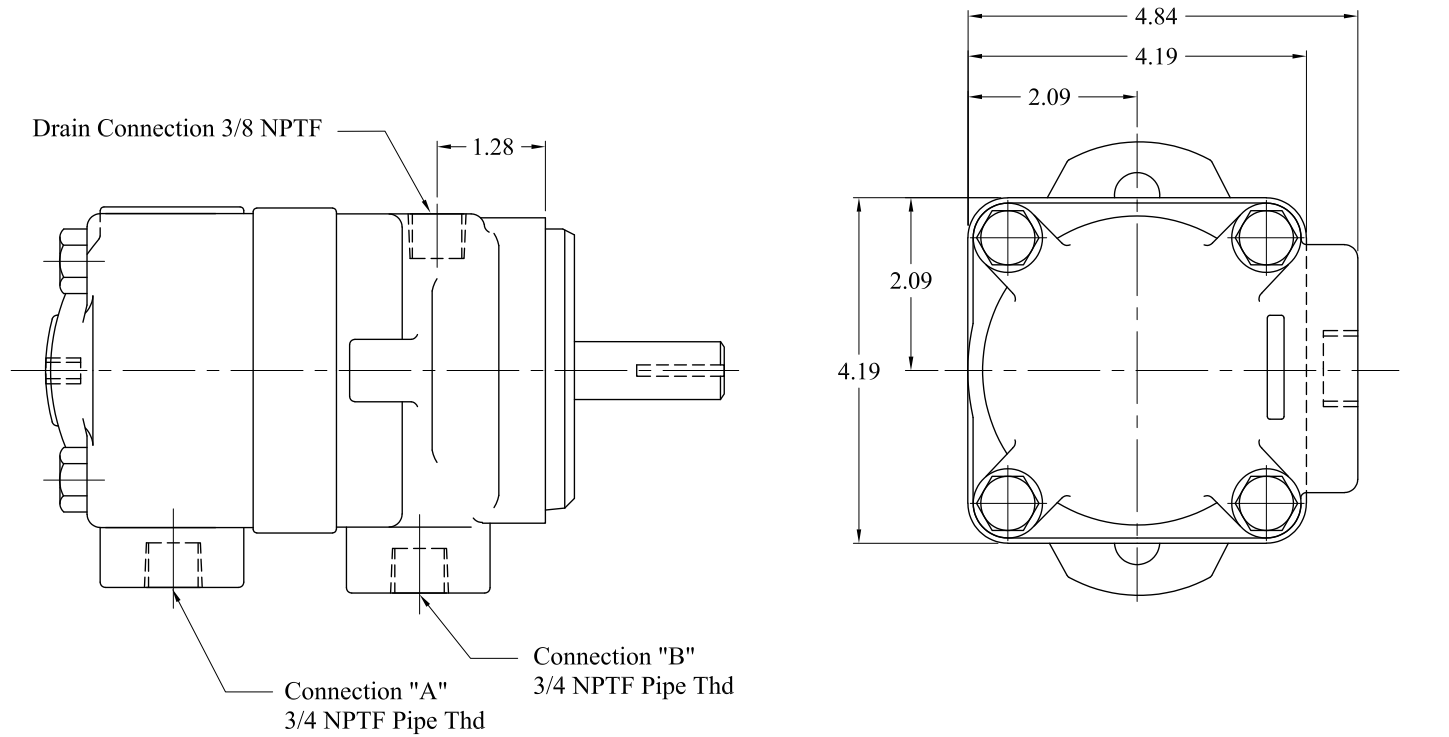

IFP M2-210 VANE MOTOR PARTS DRAWING

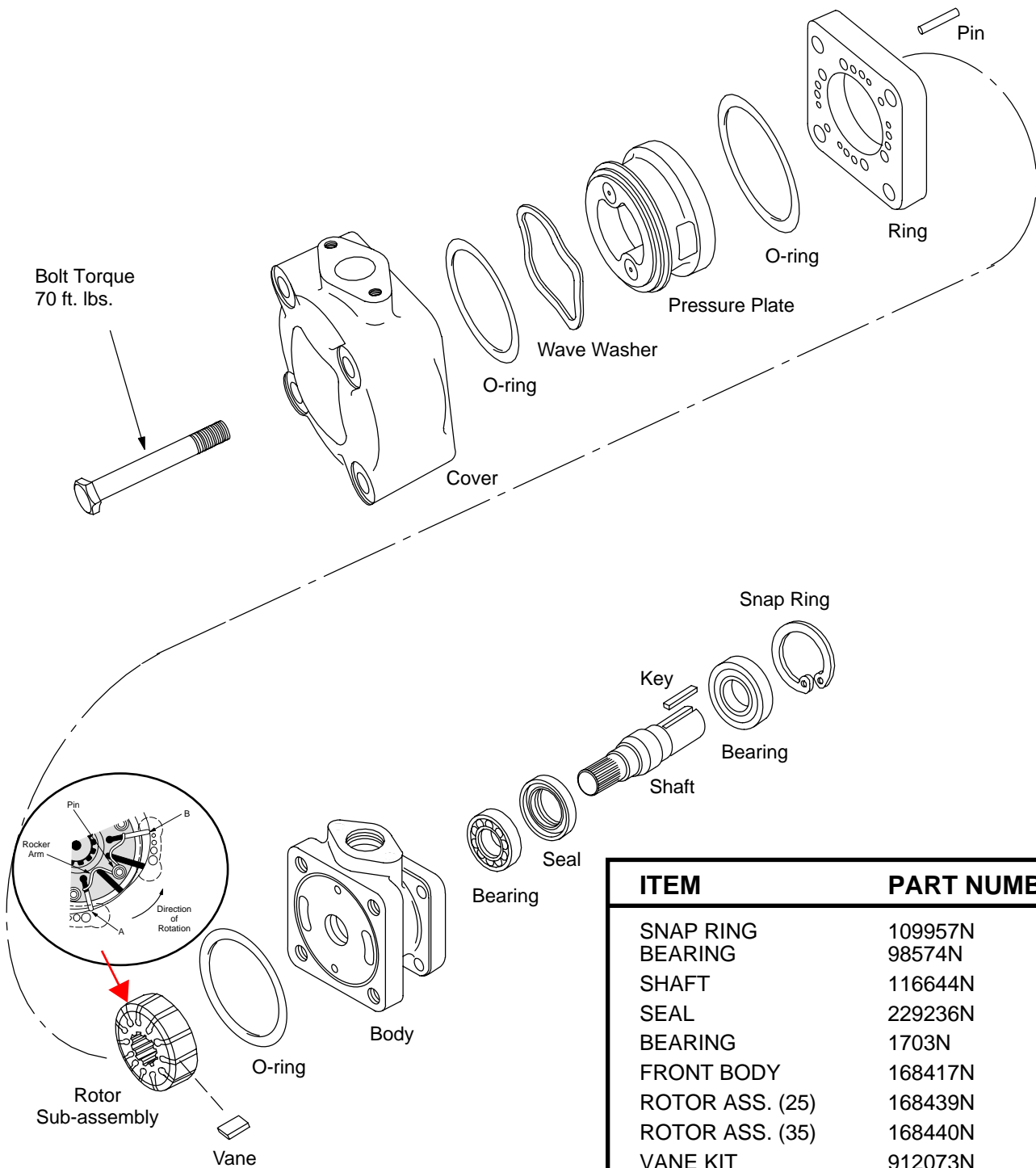

ITEM	PART NUMBER
SNAP RING	109957N
BEARING	98574N
SHAFT	116644N
SEAL	229236N
BEARING	1703N
FRONT BODY	168417N
ROTOR ASS. (25)	168439N
ROTOR ASS. (35)	168440N
VANE KIT	912073N
RING (25)	168419N
RING (35)	168418N
CARTRIDGE (25)	922834N
CARTRIDGE (35)	922835N
PRESSURE PLATE	168450N
WAVE WASHER	141792N
REAR COVER	153998N