

International fpa introduces A. F. D. Flow divider

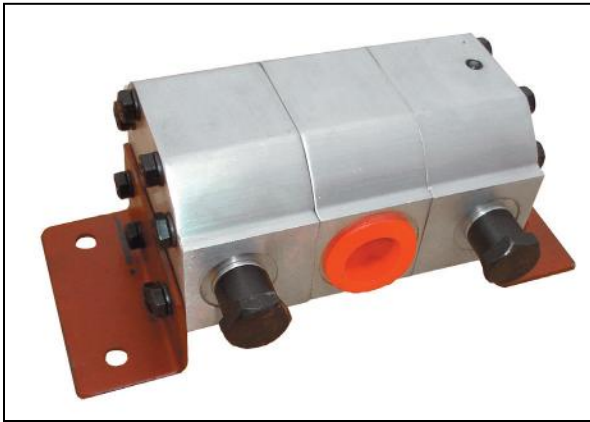

Rotary flow dividers
fixed displacement
Two Sections
Adjustable port reliefs
each section

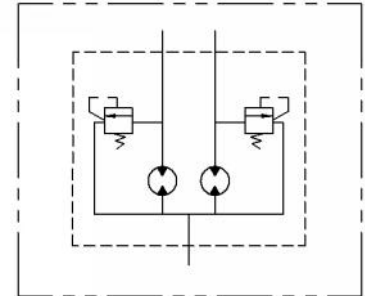

Order Code AFD-	Displacement Each / Section		SAE Ports		Minimum Flow/ Section		Maximum Flow/ Section		Cont. Diff. Pressure Between Inlet/Outlet		Maximum Outlet Pressure Any Section		Dimensions inches (millimeters)			
	In. ³	Cm. ³	Inlet	Outlet	GPM	L/M	GPM	L/M	PSI	BAR	PSI	BAR	A	B	C	D
06	.97	1.60	9/16-18	9/16-18	0.8	3.0	1.7	6.4	1800	124	3500	241	5.0(127.7)	6.0(153.5)	2.6(65.5)	2.2(57.7)
08	.129	2.13	3/4-16	3/4-16	1.2	4.5	2.5	9.5					5.2(131.9)	6.2(157.7)	2.7(69.7)	2.4(59.8)
12	.194	3.18	7/8-16	9/16-18	1.7	6.4	4.5	13.2					5.4(138.2)	6.5(164.3)	3.0(76.0)	2.5(63.0)
16	.258	4.24	7/8-14	7/8-14	2.5	9.5	5.0	18.9					6.6(166.7)	7.6(192.0)	3.3(84.1)	3.0(77.8)
20	.323	5.29	7/8-14	7/8-14	3.0	11.4	6.0	22.7					5.9(150.9)	7.0(176.7)	3.5(88.7)	2.7(69.4)
24	.388	6.36	7/8-14	7/8-14	3.5	13.2	7.0	26.5	1600	110			6.2(157.3)	7.2(183.1)	3.7(95.1)	2.9(72.6)
28	.453	7.42	7/8-14	7/8-14	4.0	15.1	8.0	30.3	1300	90			6.4(163.6)	7.4(189.4)	4.0(101.4)	3.0(75.72)
32	.517	8.42	7/8-14	7/8-14	4.5	17.0	9.0	34.1	1200	83			6.5(166.0)	7.6(191.8)	4.0(103.8)	3.0(76.9)

NOW IN STOCK

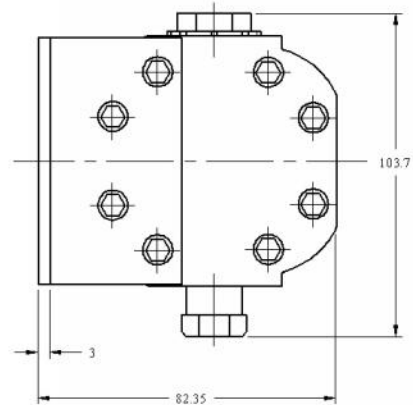
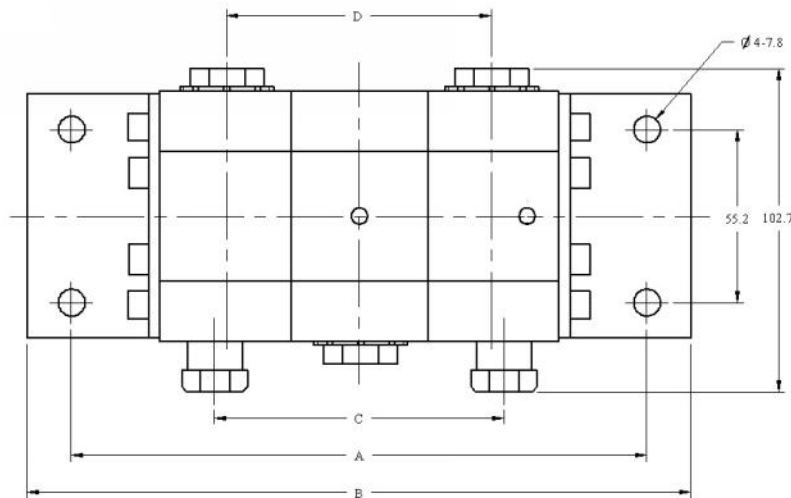

MODEL CODE

IFP AFD - 16 / 16

IFP ALUMINUM DISPLACEMENT
PRODUCTION FLOW DIVIDER PER / SECTION

E7.1

IFP AFD Flow divider Operating specifications



January 18-2010

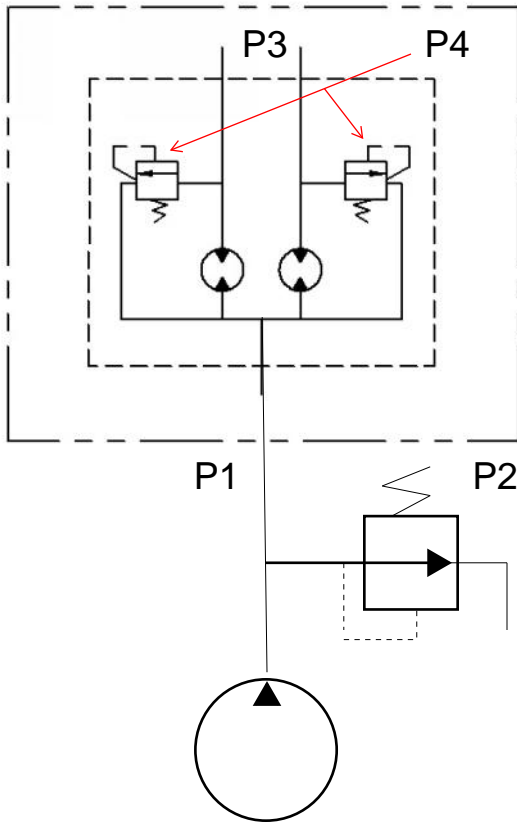

P1 = Pressure at the inlet of the Flow divider

P2 = Pressure adjustment of the main relief

P3 = The outlet pressure of the flow divider

P4 = Differential relief pressure adjustment (450 PSI)

IFP AFD rotary gear flow dividers offer the most efficient system to divide flow into two equal circuits, As opposed to spool type flow dividers that generate heat in a hydraulic system IFP AFD flow dividers work at a 98% efficiency with almost no pressure differential between P1 inlet pressure & P2 flow divider outlet pressure

IFP AFD flow dividers offer integral differential reliefs at the outlet ports of the AFD flow divider. The differential reliefs are used to synchronize cylinders and protect the flow divider from excessive differential pressure. The synchronization is accomplished if one of the cylinders completes its stroke before the other cylinder P3 pressure will increase causing a pressure differential between P1 & P3 when pressure differential reaches the adjustment value of the relief valve (P4 = Adjustment 450 PSI) fluid is bled off over the flow divider's internal relief valves to feed the inlet of the flow divider feeding the cylinder that is late.

The differential relief valves also protect the circuit from pressure intensification not allowing the pressure in P3 outlets to rise higher than the main relief adjustment + the pressure adjustment of the differential reliefs P4

(Maximum pressure P3 = P2 Relief pressure + P4 port relief adjustment 450 PSI)