

IFP VCD 25 MANUALLY OPERATED SECTIONAL VALVE



FEATURES

- Adjustable Balanced Piston Relief Valve
- Power Beyond / Closed Center Available
- Integral Load Holding Check Valve
- Optional Pilot Operated Check Valve
- Spring Return or Detent



MODEL		VCD 25	
Max. recom. flow		25 US GPM (95 LPM)	
Recommended flow		21 US GPM (80 LPM)	
Max. Pressure		5000 PSI (350 bar)	
Leakage @1500 PSI (100bar)		0.12 in ³ /min(2 cm ³ /min)	
Tie rod tightening torque		35 Nm	20 lb ft
Weight LBS(Kg)		22.4(10.2) - 115.5(52.5)	
Port Sizes	Pressure	SAE 10	3/4 NPT
	Tank	SAE 10	3/4 NPT
	Work	SAE 8	1/2 NPT

ASSEMBLED SECTIONAL VALVE CODE

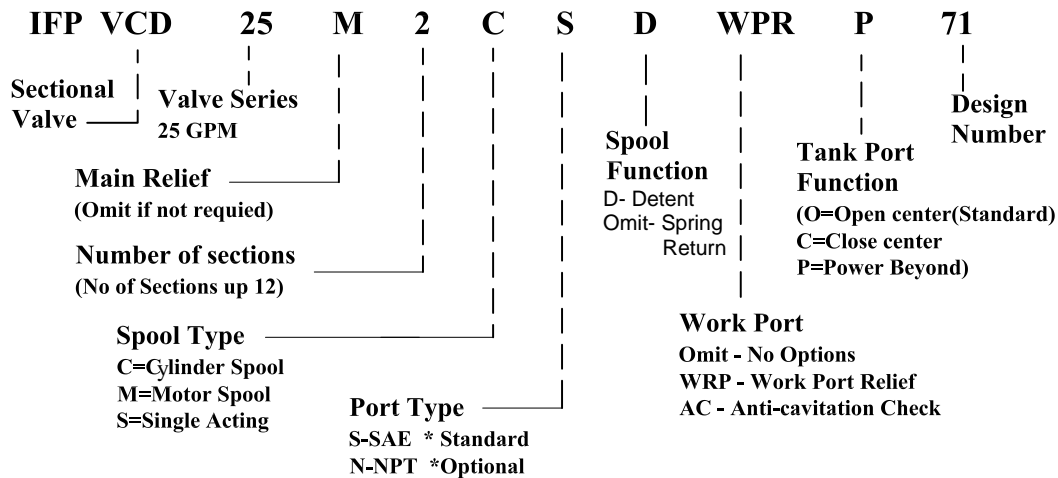

WORK SECTION AND ACCESSORY CODE

- VCD25 M - Inlet Section C/W Main relief
- VCD25 O - Outlet Section / Open Center
- VCD25 D - Work section / Spring Return
4 Way 3 Position Cylinder Spool
- WPR - Work Port Relief
- AC25 - Anti-cavitation check

Note- If Other Than SAE ports Please Specify